



**Parts List
4" Model T-18 and T-27
Mark II Turbo-Meter**

**Parts List
4" MODEL T-18 and T-27
Mark II Turbo-Meters**

**Working Pressures:
175, 275, 720, and 1440 psi**

4" Model T-18 and T-27 Mark II Turbo-Meters

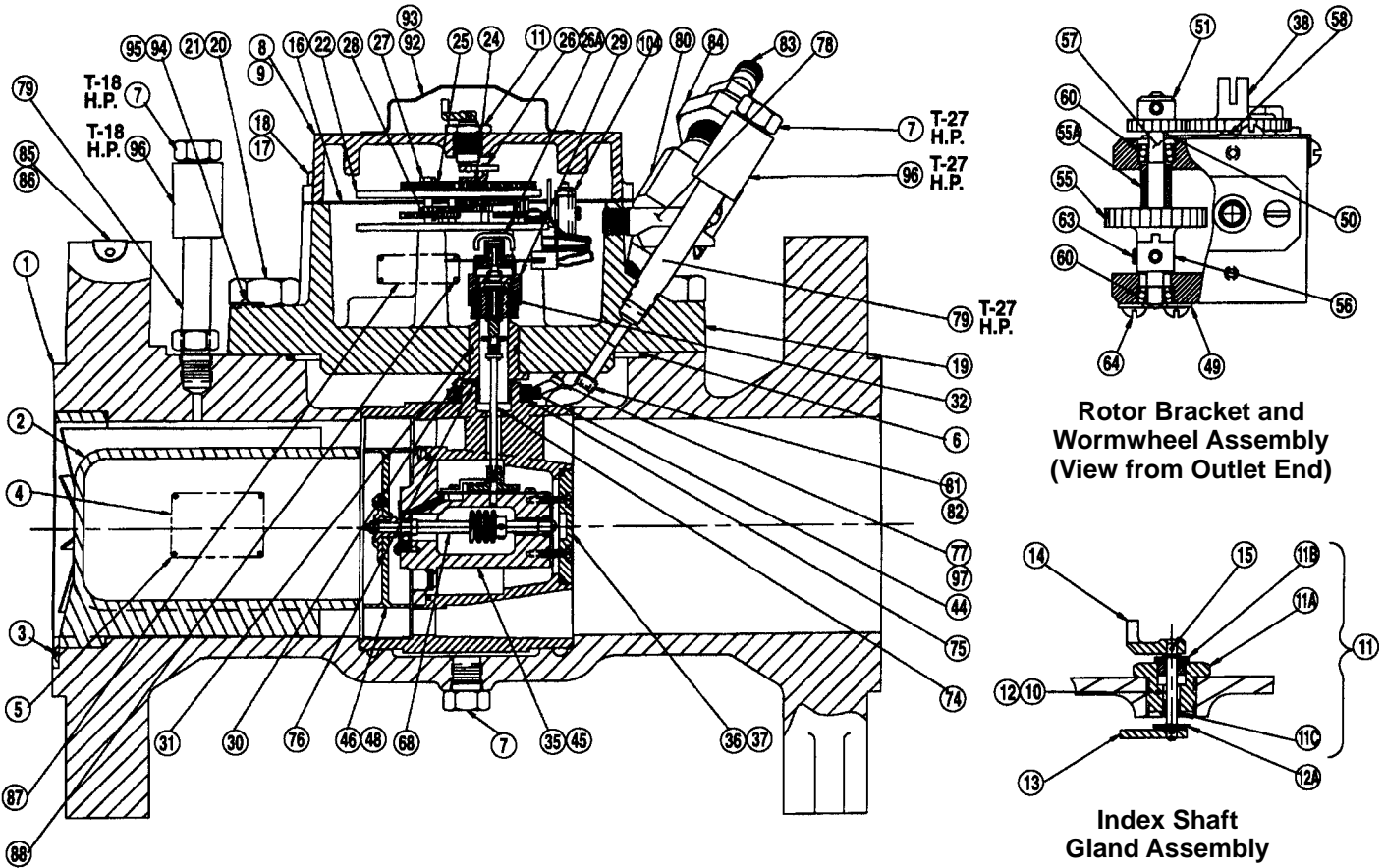

4" Model T-18 and T-27 Mark II Turbo-Meter General Assembly

ILL. NO.	QTY. REQ'D.	PART DESCRIPTION	PART NUMBER
**1	1	Main Body Assembly, Aluminum 175# W.P. with Badges, Less Nose Cone	006-22-611-00
		Main Body Assembly, C.S. ANSI 150, 275# W.P. with Badges, Less Nose Cone	006-22-611-02
		Main Body Assembly, C.S. ANSI 300, 720# W.P. with Badges, Less Nose Cone	006-22-611-50
		Main Body Assembly, C.S. ANSI 600, 1440# W.P. with Badges, Less Nose Cone	006-22-611-80
		Main Body Assembly, C.S. ANSI 600, 1440# W.P. with Badges, Less Nose Cone with Ring Joint Flanges	006-22-611-81
2	1	Nose Cone with Straightening Vanes, Molded Ryton for 275#, 720#, 1440# W.P.	006-22-305-04
		Nose Cone with Straightening Vanes, Molded Ryton for 175# W.P.	006-22-305-05
3	3	Nose Cone Retainer Screw, #8-32 x 3/8" Lg. Truss Head S.S. Mach. Screw	950426
4	1	Manufacturer Nameplate, 175# W.P. T-18	006-22-073-01555
		Manufacturer Nameplate, 275# W.P. T-18	006-22-073-30555
		Manufacturer Nameplate, 720# W.P. T-18	006-22-073-51555
		Manufacturer Nameplate, 1440# W.P. T-18	006-22-073-81555
		Manufacturer Nameplate, 175# W.P. T-27	006-42-073-01555
		Manufacturer Nameplate, 275# W.P. T-27	006-42-073-30555
		Manufacturer Nameplate, 720# W.P. T-27	006-42-073-51555
5	4	Nameplate Drive Screw, #4 x 3/16" Lg. Round Head Drive Screw	903004

ILL. NO.	QTY. REQ'D.	PART DESCRIPTION	PART NUMBER
*6	1	Top Plate to Body "O" Ring, 175# W.P. Buna	934338
		Top Plate to Body "O" Ring, H.P. Viton	906089
		Top Plate to Body "O" Ring, H.P. Buna	950189
7	2	Steel Pipe Plug, 1/4 NPT, -40°F T-18	950179
	3	Steel Pipe Plug, 1/4 NPT, -40°F T-27	950179
8	1	Index Plate Assembly (Includes Items 9, 10, 11, and 13) (w/o Slot Sensor)	006-24-504-21
		Index Plate Assembly (Includes Items 9, 10, 11 and 13) (w/Slot Sensor)	006-24-504-23
9	1	Index Plate (w/o Slot Sensor)	006-24-004-21
		Index Plate (w/Slot Sensor)	006-24-004-23
10	1	Index Drive Shaft Assembly (Includes Items 12, 14 and 15)	006-24-554-01
11	1	Index Shaft Gland Assembly (Includes Items 11A, 11B and 11C)	006-24-323-00
11A	1	Index Shaft Gland	006-24-023-00
11B	1	Top Bushing	006-24-052-01
11C	1	Bottom Bushing	001-60-052-62
12	1	Index Shaft	006-24-054-02
12A	1	Retaining Ring	950578
13	1	Bottom Index Shaft Dog	006-24-071-00
14	1	Top Index Shaft Dog	006-24-061-04
*15	1	Shear Pin, Top Index Shaft Dog	006-24-056-00
*16	1	Gasket, Index Plate to Top Plate	006-24-160-03
17	3	Screw, 5/16"-18 x 3/4" Lg. Cap Screw, Index Plate to Top Plate	910028

* Recommended Spare Parts

** Main Body Assembly, includes Inlet and Body Badges less Nose Cone.

4" Model T-18 and T-27 Mark II Turbo-Meter General Assembly

ILL. NO.	QTY. REQ'D.	PART DESCRIPTION	PART NUMBER
18	1	Seal Screw, 5/16"-18 x 3/4" Lg. Cap Screw, Index Plate to Top Plate	002-65-057-02
19	1	Top Plate Assembly, Aluminum, 175# T-18	006-22-303-01
		Top Plate Assembly, ANSI 150, 275# W.P. T-18	006-22-303-16
		Top Plate Assembly, ANSI 300 and 600, 720# - 1440# W.P. T-18	006-22-303-86
		Top Plate Assembly, Aluminum, 175#, With Pressure Tap T-27	006-52-303-01
20	7	Top Plate Assembly, ANSI 150, 275# W.P. With Pressure Tap T-27	006-52-303-16
		Top Plate Assembly, ANSI 300 and 600, 720# - 1440# W.P. With Pressure Tap T-27	006-52-303-86
		Screw, 1/2"-13 x 1-1/4" Lg. Cap Screw, Top Plate to Body, 175# W.P.	910106
21	1	Screw, 1/2"-13 x 1-1/4" Lg. Cap Screw, Top Plate to Body, 275# W.P.	903592
		Screw, 3/4"-10 x 2" Lg. Cap Screw, Top Plate to Body, 720# - 1440# W.P.	935678
		Seal Screw, 1/2"-13 x 1-1/4" Lg. Cap Screw, Top Plate to Body, 175# W.P.	006-22-056-00
*22	1	Seal Screw, 1/2"-13 x 1-1/4" Lg. Cap Screw, Top Plate to Body, 275# W.P.	002-66-057-10
		Seal Screw, 3/4"-10 x 2" Lg. Cap Screw, Top Plate to Body, 720# - 1440# W.P.	006-22-058-00
		Intermediate Gear Assy (w/o Change Gears, Dogs & Nuts) 100 cf/Rev. of Meter Output Shaft, Plastic	006-24-212-40
24	1	100 cf/Rev. of Meter Output Shaft, Brass	006-24-212-21
		10 M ³ /Rev. of Meter Output Shaft, Brass	006-24-212-22
		1.0 M ³ /Rev. of Meter Output Shaft, Plastic	006-24-212-41
25	1	Large Change Gear NOTE: "XX" refers to gear blank size, "YY" refers to number of gear teeth. Digits must be substituted for both "XX" and "YY" in ordering. See SD-1034-C	006-24-3XX-YY
26	1	Small Change Gear (See Note Above)	006-24-3XX-YY
26A	1	Intermediate Gear, Output Dog (Top)	002-66-071-03
27	1	Intermediate Gear, Driver Dog (Bottom)	006-24-061-20
28	3	Small Change Gear Nut, #4-40 S.S.	907639
*29	1	Screw, #8-32 x 3/8" Lg. Fillister Head, Intermediate Gear Mounting Screw	903371
		Follower Magnet Assembly (Includes Items 29A thru 29D)	006-24-313-20
29A	1	Follower Magnet Assembly (Includes Items 29A thru 29F) (w/Slot Sensor)	006-24-313-22
29B	1	Follower Magnet Holder Assembly, With Magnet	006-24-213-20
		Follower Magnet Holder Assembly, With Magnet (w/Slot Sensor)	006-24-013-21
29C	2	Bearing Retaining Ring, "E" Clip	904691
29D	1	Bearing, Follower Magnet Assembly	905462
29E	1	Spacer	006-24-106-20
29F	2	Chopper	006-24-108-02
*30	1	Screw, #3-48 x 1/8" Lg. Fillister Head	903337
		Driver Magnet Well and Post Assembly, 175#, 275#	006-31-244-00
*31	1	Driver Magnet Well and Post Assembly, 720#, 1440#	006-24-244-20
*32	1	Driver Magnet Well "O" Ring, BUNA	950193
		Driver Magnet Well "O" Ring, VITON	908264
32A	1	Driver Magnet Holder and Bearing Assembly (Includes Items 32A thru 32D)	006-31-334-00
32B	1	Driver Magnet Holder and Groove Pin Assembly (with Magnet)	006-31-234-02

* Recommended Spare Parts

ILL. NO.	QTY. REQ'D.	PART DESCRIPTION	PART NUMBER
32B	1	Bearing Retaining Ring	904961
32C	2	Bearing (Driver Magnet Well and Post Assembly)	905462
32D	1	Spacer	006-22-106-03
33	1	Complete Internal Housing, Viton Includes Items 6, 24, 25, 34-36, 39-41, 52, 58, 77 & 97 (Calibrated) T-18	006-22-302-20
		Complete Internal Housing, Buna Includes Items 6, 24, 25, 34-36 39-41, 52, 58, 77 & 97 (Calibrated) T-18	006-22-302-21
		Complete Internal Housing, Buna 175# W.P., Includes Items 6, 24, 25, 34-36, 39-41, 52, 58, 77, 81, 82 & 97 (Calibrated) T-27†	006-52-302-22
		Complete Internal Housing, Buna 275# thru 1440# W.P. Includes Items 6, 24, 25, 34-36, 39-41, 52, 58, 77, 81, 82 & 97 (Calibrated) T-27†	006-52-302-21
34	1	Complete Internal Housing, Viton 275# thru 1440# W.P. Includes Items 6, 24, 25, 34-36, 39-41, 52, 58, 77, 81, 82 & 97 (Calibrated) T-27†	006-52-302-20
		Internal Housing and Adapter Plate Assembly (Includes Items 42, 43 & 44) T-18	006-22-202-03
		Internal Housing and Adapter Plate Assembly (Include Items 42, 43 & 44) T-27	006-52-202-03
*35	1	Rotor Bracket and Wormwheel Assy. (Includes Items 38, 45, 48-51, 53-57, 59-67 and 68A) T-18	006-22-309-03
		Rotor Bracket and Wormwheel Assy. (Includes Items 38, 45, 48-51, 53-57, 59-67, and 68A) T-27	006-52-309-03
36	1	Internal Housing Plate Assy. (Includes Items 37, 59 and 65)	006-22-210-00
37	1	Internal Housing Plate	006-22-010-02
38	1	44T Slotted Gear T-18	006-31-444-44
		37T Slotted Gear T-27	006-52-444-37
*39	1	Tetraseal, Buna	904215
*40	1	Tetraseal, Viton	906737
		Tetraseal, Buna	904207
41	2	Tetraseal, Viton	906738
		Screw, #4-40 x 1/2" Lg. Round Head Mach. Screw	903624
41A	2	#4 External Lock Washer	906144
42	1	Internal Housing (Less Oil Tube) T-18	006-22-002-03
		Internal Housing (Less Oil Tube) With Pressure Tap T-27	006-52-002-03
43	1	Adapter Plate and Bushing Assembly	006-22-262-01
44	1	Retaining Ring	904435
45	1	Bearing Bracket and Pin Assembly T-18	006-22-209-03
		Bearing Bracket and Pin Assembly T-27	006-52-209-27
46	1	Rotor and Insert Assembly T-18	006-22-350-00
		Rotor and Hub Assembly T-27	006-52-350-27
47	1	Seal Spacer	006-22-082-00
48	1	Rotor and Shaft Assembly (Includes Items 46-47, one of 61, 68-72) T-18	006-22-450-00
49	2	Bearing Retainer Plate T-18	006-22-117-01
49A	1	Bearing Retainer Plate, Inlet Side T-27	006-32-117-01
49B	1	Bearing Retainer Plate, Outlet Side T-27	006-31-117-01
50	1	Screw, #4-40 x 1/8" Lg. Pan Head Screw	1191260
51	1	22T Stainless Steel Gear T-18	006-22-422-22
		29T Stainless Steel Gear T-27	006-52-422-29
52	1	Gear Retainer	006-22-080-00

* Recommended Spare Parts

† NOTE: T-27 Complete Internal Housing cannot be used for update from an existing T-18 Turbo-Meter to a T-27 Turbo-Meter.

4" Model T-18 and T-27 Mark II Turbo-Meters

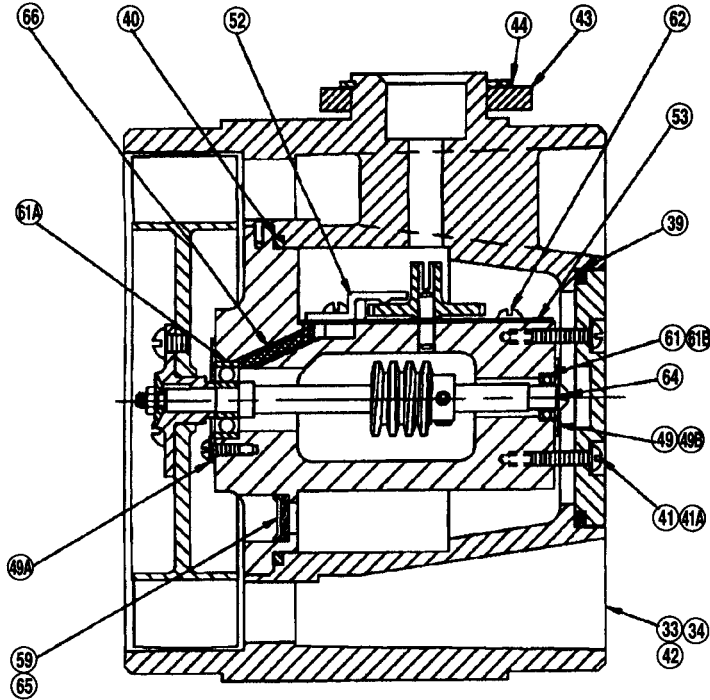

Internal Housing Assembly

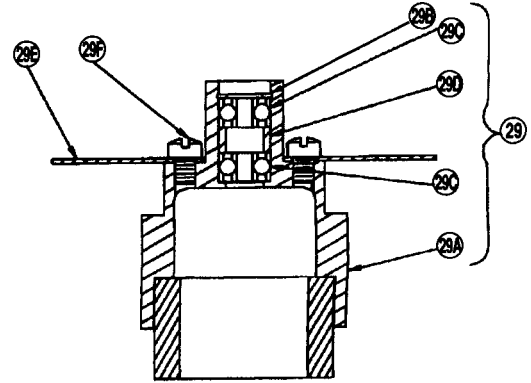

Follower Magnet and Bearing Assembly

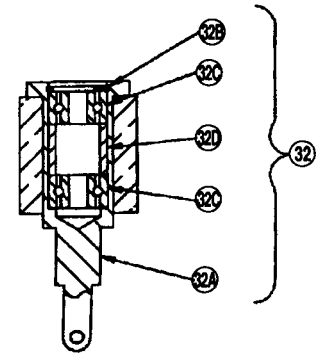

Driver Magnet Holder and Bearing Assembly

4" Model T-18 and T-27 Mark II Turbo-Meter General Assembly

ILL. NO.	QTY. REQ'D.	PART DESCRIPTION	PART NUMBER
53	1	Oil Reservoir Cover Plate	006-22-079-01
54	1	Worm, Stainless Steel T-18	006-24-017-00
		Worm, Stainless Steel T-27	006-24-018-80
55	1	Worm Wheel	006-24-035-00
55A	1	Worm Wheel Spacer	006-22-106-00
56	1	Worm Wheel Collar	006-24-070-02
57	1	Worm Wheel Shaft	006-22-046-00
58	1	Gear Post	006-22-028-00
59	2	Filter Screen	006-22-083-01
60	2	Bearing (Worm Wheel Shaft)	908660
61	2	Rotor Shaft Bearing	T-18 905457
61A	1	Rotor Shaft Bearing, Inlet Side	T-27 950236
61B	1	Rotor Shaft Bearing, Outlet Side	T-27 950235
62	4	Screw, #4-40 x 1/8" Lg. Round Head Mach. Screw	907401
63	5	Set Screw, #6-32 x 1/8" Lg. Nylon Tip Set Screw	950375

ILL. NO.	QTY. REQ'D.	PART DESCRIPTION	PART NUMBER
64	5	Screw, #4-40 x 1/4" Lg. Round Head Mach. Screw	903025
65	2	Filter Screen Retaining Ring	904419
66	2	Oiler Felt	1191430
68	1	Rotor Shaft T-18	006-22-024-00
		Rotor Shaft T-27	006-52-024-27
68A	1	Rotor Shaft Retaining Nut	T-18 006-22-119-00
69	1	Rotor Locking Pin	006-22-020-00
70	1	Washer, Stainless Steel T-18	904048
		Spherical Washer, Stainless Steel T-27	006-32-077-01
71	1	Rotor Retaining Nut	904168
72	1	Rotor Nut "O" Ring	T-18 904379
74	1	Coupling Shaft, 175# & 275# W.P.	006-22-345-01
		Coupling Shaft, 720# & 1440# W.P.	006-22-345-81
75	2	Screw, #8-32 x 3/4" Lg. Fill. Head Mach. Screw (Adapter Plate to Top Plate)	903376

* Recommended Spare Parts

4" Model T-18 and T-27 Mark II Turbo-Meters

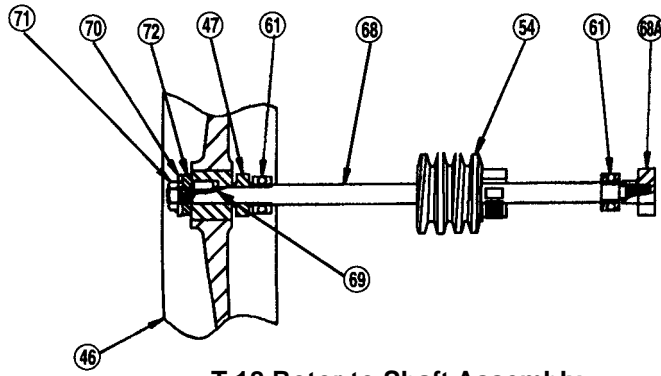

T-18 Rotor to Shaft Assembly

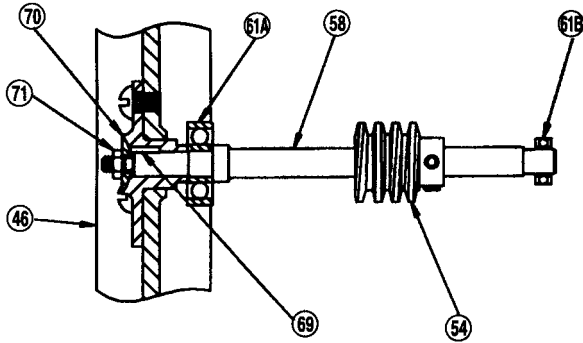

T-27 Rotor to Shaft Assembly

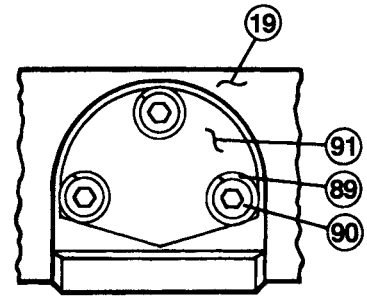

Wiring Connector Hole Cover on Side of Top Plate

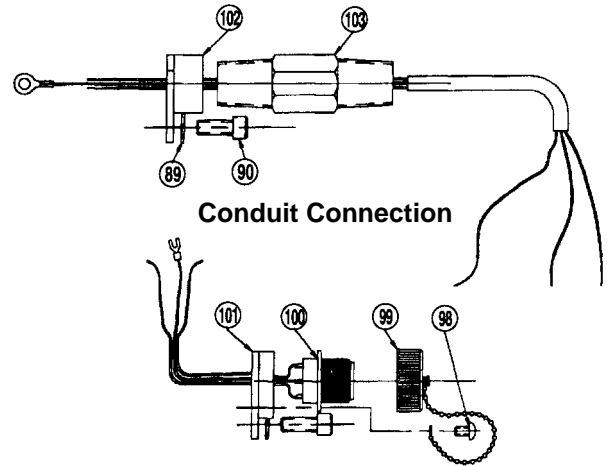

Conduit Connection

Bendix Connection

Slot Sensor Pulsar Connection

4" Model T-18 and T-27 Mark II Turbo-Meter General Assembly

ILL. NO.	QTY. REQ'D.	PART DESCRIPTION	PART NUMBER
*76	1	Tetraseal, Buna	904214
		Tetraseal, Viton	906736
77	3.5"	Tygothane Tubing	99993
78	2	Vent Cap Assembly	006-24-505-01
79	1	Nipple, 1/4" x 3" Lg. -20°F.	950760
		Nipple, 1/4" x 3" Lg. -40°F.	950186
80	1	Valve, 175# W.P.	950428
		Valve, 275# - 1440# W.P.	950710
81	2	Compression Ring, Pressure Tap	T-27 950772
82	3.5"	Pressure Tubing	T-27 800700
83	1	Alemite Fitting	006-24-145-00
84	1	Bushing	950195
85	1	Inlet Badge	015-16-090-02
86	2	#2 x 1/8" Lg. Round Head Drive Screw	903003
87	1	Internal Mech. Badge, Fastened to Top Plate	T-18 006-22-073-11
		Internal Mech. Badge, Fastened to Top Plate	T-27 006-52-073-11
88	4	#0 x 1/8" Lg. Round Head Drive Screw	903001
89	3	Lock Washer	904030
90	3	Screw, 1/4"-20 x 5/8" Lg. Socket Head Cap Screw	908179
91	1	Cover, Probe Mounting Hole	006-24-129-00
92	1	Cover, Stuffing Box	225-16-131-01
93	2	Screw, #8-32 x 3/16" Lg. Round Head Mach. Screw	914450

ILL. NO.	QTY. REQ'D.	PART DESCRIPTION	PART NUMBER
94	1	Inlet Badge	006-22-073-04
95	2	#0 x 1/8" Lg. Round Head Drive Screw	903001
96	1	Pipe Coupling, 720# & 1440#, -20°F.	950711
		Pipe Coupling, 720# & 1440#, -40°F.	950181
97	2	Compression Ring, Oiling	950682
98	2	Screw, #8-32 x 1/4" Lg. Round Head, (Slot Sensor)	903055
99	1	Bendix Connector Cap and Chain, (Slot Sensor)	006-20-331-00
100	1	Bendix Connection (Slot Sensor)	950124
101	1	Bendix Connection Flange Adapter, (Slot Sensor)	006-22-122-06
102	1	Conduit Connection Flange Adapter, (Slot Sensor)	006-22-122-05
103	1	Conduit Connection, (Slot Sensor)	006-22-222-02
104	1	Sensor and Bracket Assembly, (Slot Sensor)	950682
		OPTIONAL ITEMS	
		Blank Top Plate, 175# W.P.	006-22-003-08
		Blank Top Plate, 275# W.P.	006-22-003-09
		Blank Top Plate, 720# & 1440# W.P.	006-22-003-82
		Oil, 4 oz. Bottle	006-22-405-01
		Oil, 1 Gallon Can	006-22-405-02
		Lubrication Hand Gun	006-24-400-00

* Recommended Spare Parts



805 Liberty Boulevard
DuBois, PA 15801
814-375-8875
Fax 814-375-8460

Authorized Distributor

Limited Warranty

Seller warrants the Goods to be free from defects in materials manufactured by Seller and in Seller's workmanship for a period of one (1) year after tender of delivery (the "Warranty Period"). THIS LIMITED WARRANTY (a) IS IN LIEU OF, AND SELLER DISCLAIMS AND EXCLUDES ALL OTHER WARRANTIES, STATUTORY, EXPRESS OR IMPLIED, INCLUDING, WITH LIMITATION, ANY WARRANTY OF MERCHANTABILITY OR FITNESS FOR A PARTICULAR PURPOSE, OR OF CONFORMITY TO MODELS OR SAMPLES; (b) does not apply to any Goods which have been (i) repaired, altered or improperly installed; (ii) subjected to improper use or storage, (iii) used or incorporated with other materials or equipment, after buyer or anyone using the Goods has, or reasonably should have, knowledge of any defect or nonconformance of the Goods; or (iv) manufactured, fabricated or assembled by anyone other than Seller, (c) shall not be effective unless buyer notifies Seller in writing of any purported defect or nonconformance with (thirty days) after Buyer discovers or should have reasonably discovered such purported defect or nonconformance; and (d) shall only extend to Buyer and not to any subsequent buyers or users of the Goods. Buyer shall provide Seller access to the Goods as to which Buyer claims a purported defect or nonconformance, upon request by Seller, buyer shall, at its own risk and expense, promptly return the Goods in question to Seller's Plant.